

New Threads

Quilt Retail ■ Workshops ■ Design

Innisfree, Stoke Road, Smannell

Andover, Hants. SP11 6JL

☎ 01264 361635 ✉ new.threads@jlis.co.uk

Oakshott Baby Quilt



Finished size: 46" x 60"

Requirements

Fabrics:

Longshott – Fat quarter each of

Daffodil Long04, Prairie Long06, Mint Ice Long07, Flamingo Long15, Tropical Pink Long17, Sweet William Long24, Summer Blue Long 28, plus one extra FQ of one of these colours.

Colourshott Plain: 3m of White Sand Cott01 (sufficient for borders, plain squares and backing fabric)

1.75m of Lilac Cott21 for outer border.

Wadding 49" x 63"

Instructions:

This is a traditional Cobblestones pattern. It is comprised of octagons with 2" sides alternating with 2" squares. All coloured octagons are cut from Longshott striped fabric. The Sand coloured squares, the Sand border and the Lilac border are cut from Colourshott plain fabric. All seams ¼".

To print an Octagon template the correct finished size:

1. Open a new Word Document
2. Select the Octagon shape from the Autoshapes on the Draw toolbar.
3. Make an Octagon on the Drawing Canvas.
4. Right click the Octagon and click 'Format Autoshape.' Set size to 4.83" height and 4.83" width.
5. Print. Each side should measure 2" exactly. This is the FINISHED size of the template without any seam allowances added. You will need to add a ¼" seam allowance to this shape to make your rotary cutting template, as instructed below.

Cutting:

1. Make two templates from plastic or card for the octagon, one which includes ¼" seam allowance and one without a seam allowance.
2. Make a square template which is exactly 2" square.
3. Using the larger of the two templates (the one with seam allowances included) rotary cut octagons from fabric, in groups of four, cutting even numbers of 'flowers' from each colour. For partial octagons placed on edge of centre panel, half an octagon can be used as the template.

This will be a little larger than needed, but the edges will be trimmed even once centre panel is pieced.

4. Reserve a 10" x 52" strip of the Sand cotton for inner borders.
5. Rotary cut 58 squares, 2.5", from the Sand cotton.
6. Rotary cut 2.5" squares from leftover Longshott stripe fabric. 82 squares in total are needed, from an even mix of colours.
7. Cut and set aside four 4" wide strips from the entire lengthwise grain of the Lilac cotton, for outer borders.

Preparation:

Using the smaller of the two octagon templates and the 2" square template, mark small pencil dots on the back of each cut octagon and square at each template corner. These will mark where to pivot during seaming.

Layout:

Pin all cut octagons onto a design board or sheet. The stripes radiate out from the centre of each 'flower' like this:

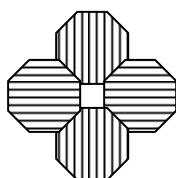

Distribute colours evenly, as per diagram at the top of these instructions.

Piecing:

1. Working in rows and matching pivot marks, piece rows of Octagon-Square-Octagon as follows:

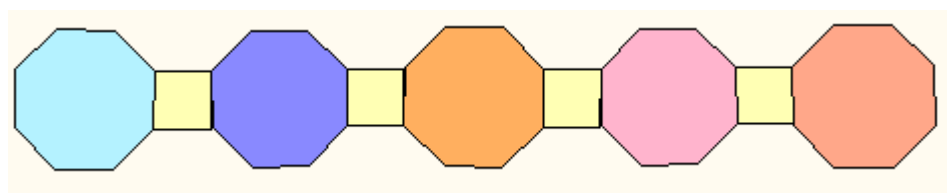

Diag. 1—showing piecing of bottom row.

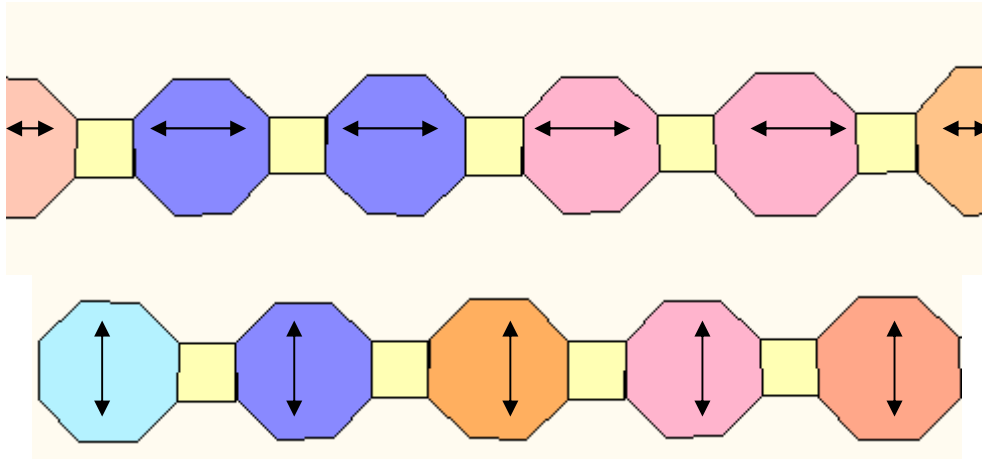

Diag. 2 Showing piecing of bottom two rows, arrows indicating stripe direction of fabric. (Colours are nominal, diagram shows piecing method, not colour placement.)

2. When horizontal rows are pieced, join rows, pivoting at marked dots.
3. Trim centre panel of quilt to 46.5" by 24.5", or as close thereto as possible, keeping design correct.
4. Add Sand borders. Measure across centre of quilt vertically and horizontally. The quilt should measure very near to 46.5" by 24.5". Add 2.5" wide Sand borders to fit, mitring corners.
5. Quilt panel should now measure 50.5" x 28.5". If not, trim to 50.5" x 28.5".
6. Join Longshott squares, keeping colours randomly distributed and alternating stripe direction, like this.

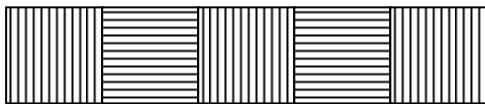

Join 14 squares to add to top and bottom of quilt. Then join 27 squares to add to each side, keeping stripe directions correct relative to the top and bottom borders.

7. Press. Measure across horizontal and vertical middle of quilt top. It should measure very near to 54.5" x 32.5". Attach plain Lilac borders, mitre corners.

FINISHING QUILT:

1. Make a quilt back, approx. 49" by 63" from remaining Sand cotton.
2. Layer quilt with wadding. Quilt as desired.
3. When quilting is finished, smooth the quilt and trim finished border to exactly 3.25" from seam line.
4. Attach thin Lilac 1/4" single binding.

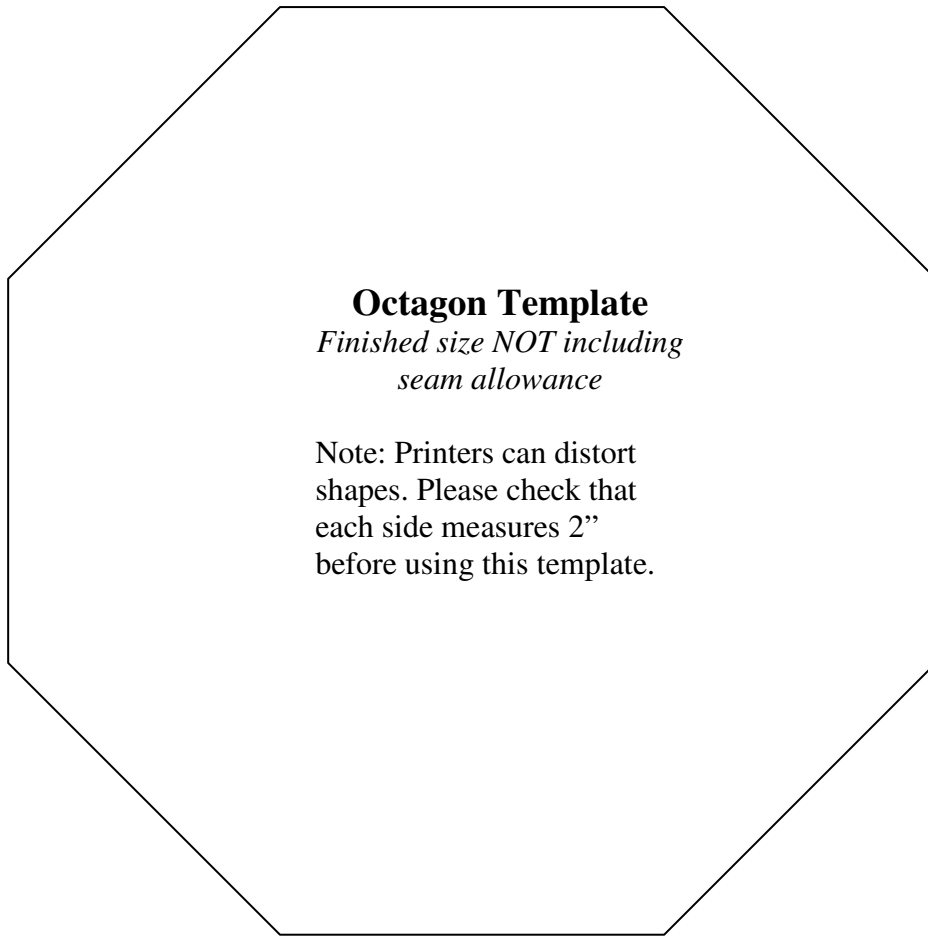

Octagon Template

*Finished size NOT including
seam allowance*

Note: Printers can distort
shapes. Please check that
each side measures 2"
before using this template.